

JDN AIR HOISTS mini

The JDN mini Series for General Duty

Carrying capacities:

125 kg, 250 kg, 500 kg, 980 kg

Air pressure: 6 bar

The **mini** widens the range of applications in the light duty sector as a handy, flexible and universally deployable hoist making it an ideal tool for a wide range of light/medium manufacturing applications. For heavier duty industrial applications we recommend the JDN PROFI series.

mini Manipulator

With the mini Manipulator loads can be lifted, lowered, manually traversed and positioned with only one hand. Further information on request.

Explosion Classification:  II 3 GD IIA T4(X)



mini 125



mini 1000
in manual trolley



mini
Manipulator

TECHNICAL DATA

| Type | | mini 125 | mini 250 | mini 500 | mini 1000 |
|--|---------------------|---------------|----------|----------|-----------|
| Capacity | lbs | 275 | 550 | 1100 | 2160 |
| | kg | 125 | 250 | 500 | 980 |
| Number of chain strands | | 1 | 1 | 1 | 1 |
| Motor output | kW | 0.4 | 0.4 | 1 | 1 |
| Air pressure | PSI | 85 | 85 | 85 | 85 |
| | bar | 6 | 6 | 6 | 6 |
| Lifting speed without load ¹ | ft/min | 130 | 65 | 65 | 33 |
| | m/min | 40 | 20 | 20 | 10 |
| Lifting speed at full load ¹ | ft/min | 49.5 | 26 | 33 | 16 |
| | m/min | 15 | 8 | 10 | 5 |
| Lowering speed at full load | ft/min | 99 | 52 | 59 | 33 |
| | m/min | 30 | 16 | 18 | 10 |
| Lowering speed without load | ft/min | 78.7 | 39.4 | 39.4 | 19.7 |
| | m/min | 24 | 12 | 12 | 6 |
| Air consumption at full load – lifting | cfm | 17.5 | 17.5 | 42.5 | 42.5 |
| | m ³ /min | 0.5 | 0.5 | 1.2 | 1.2 |
| Air consumption at full load – lowering | cfm | 24.7 | 24.7 | 56.5 | 56.5 |
| | m ³ /min | 0.7 | 0.7 | 1.6 | 1.6 |
| Air connection | | G 3/8 | G 3/8 | G 1/2 | G 1/2 |
| Hose dimension (Ø inside) | inch. | 0.35 | 0.35 | 0.5 | 0.5 |
| | mm | 9 | 9 | 13 | 13 |
| Weight with 10 ft / 3 m lift | lbs | 21 | 23.1 | 46.2 | 50.6 |
| | kg | 9.5 | 10.5 | 21 | 23 |
| Chain dimension | mm | 4 x 12 | 4 x 12 | 7 x 21 | 7 x 21 |
| Weight of chain | lbs/ft | 0.23 | 0.23 | 0.67 | 0.67 |
| | kg/m | 0.35 | 0.35 | 1.1 | 1.1 |
| Height of lift | ft | 10 / 16 / 26 | | | |
| | m | 3 / 5 / 8 | | | |
| Length of control at standard lift | ft | 6.5 / 13 / 20 | | | |
| | m | 2 / 4 / 6 | | | |
| Noise level at full load ² – lifting | dB(A) | 79 | 79 | 77 | 77 |
| Noise level at full load ² – lowering | dB(A) | 80 | 80 | 83 | 83 |

Group mechanism: M3 (1 Bm)

¹ Lifting speed at 2 m length of control. Longer control hoses decrease the lifting speeds.

² Measured at 1 m distance acc. to DIN 45635 part 20

THE ADVANTAGES AT A GLANCE

- Price competitive alternative when compared to other types of powered hoists.
- Suitable for lube-free operation.
- Suitable for application in hazardous areas.
- Minimum components for ease of maintenance.
- Wear resistant motor braking system.
- Lightweight for easy handling.
- Also suitable for horizontal pulling.
- Extremely sensitive lever control with emergency shut-off valve, max. control length 6 m.
- Available lifting heights: 3 m, 5 m, 8 m.
- With chain box as standard.
- With manual trolley as option.



DIMENSIONS

| Type | | mini 125 | mini 250 | mini 500 | mini 1000 |
|------|-------------|-------------|-------------|-------------|-------------|
| A | inch. mm | 12.9 328 | 12.9 328 | 18.0 458 | 18.0 458 |
| B | inch. mm | 9.1 232 | 9.1 232 | 12.4 316 | 12.4 316 |
| C | inch. mm | 14.4 367 | 14.4 367 | 19.9 505 | 19.9 505 |
| D | inch. mm | 3.6 92 | 3.6 92 | 4.8 122 | 4.8 122 |
| E | inch. mm | 8.4 213 | 8.4 213 | 11.5 292 | 11.5 292 |
| F | inch. mm | 4.3 109 | 4.3 109 | 5.8 148 | 5.8 148 |
| G | inch. mm | 4.1 104 | 4.1 104 | 5.6 144 | 5.6 144 |
| H | inch. mm | 7 177 | 7 177 | 9.2 234 | 9.2 234 |
| J | inch. mm | 5.8 148 | 5.8 148 | 7.6 194 | 7.6 194 |
| K | inch. mm | 3.3 83 | 3.3 83 | 4.7 119 | 4.7 119 |
| L | inch. mm | 1.1 29 | 1.1 29 | 1.6 40 | 1.6 40 |
| M | inch. mm | 0.7 19 | 0.7 19 | 1.1 28 | 1.1 28 |

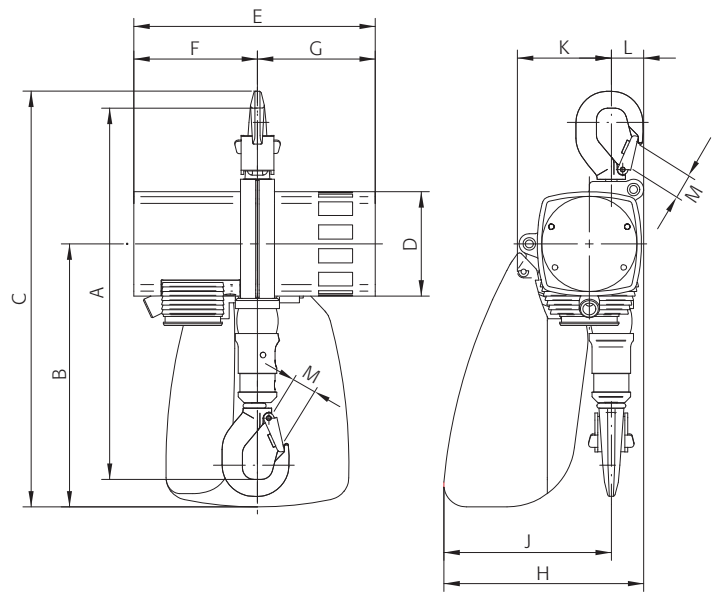

MANUAL TROLLEYS FOR JDN AIR HOISTS mini

TECHNICAL DATA

| Type | | LN 500 | LN 1000 |
|-------------------------|-------------|----------------------|-----------------------|
| For use with: | | mini 125 mini 250 | mini 500 mini 1000 |
| Beam flange width b | inch. mm | 2 - 8 50 - 220 | 2 - 8 58 - 220 |
| max. flange thickness t | inch. mm | 1.3 34 | 1.2 30 |
| min. curve radius | inch. m | 35.4 0.9 | 39.4 1.0 |
| Weight | lbs kg | 17 7.7 | 21 10.5 |

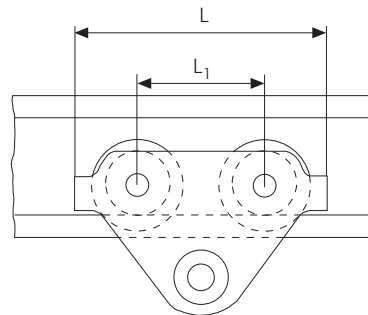

DIMENSIONS

| Type | | LN 500 | LN 1000 |
|------|-------------|-------------|-------------|
| A | inch. mm | 3.1 79.5 | 3.1 79 |
| D | inch. mm | 0.7 17 | 0.7 17 |
| D1 | inch. mm | 1 25 | 1.2 30 |
| D2 | inch. mm | 1.2 30 | 1.4 35 |
| H1 | inch. mm | 1.2 30 | 1 25 |
| l | inch. mm | 2.7 67.5 | 3.2 81.5 |
| L | inch. mm | 10.2 260 | 10.2 260 |
| L1 | inch. mm | 5.1 130 | 5.1 130 |
| O | inch. mm | 2.2 55 | 2.7 68 |
| T | inch. mm | 5.7 144 | 5.9 151 |

