

# COFFING<sup>®</sup>

## HOISTS

---

### **OPERATING & MAINTENANCE INSTRUCTIONS WITH PARTS LIST**

Publication Part No. AT-680

### **AT - Army Type Chain Hoist**

*For Capacities:*

$1/2$  - 8 Ton



#### **IMPORTANT—CAUTION**

To safeguard against the possibility of personal injury or property damage, follow the recommendations and instructions of this manual. This manual contains important information for the correct installation, operation, and maintenance of this equipment. All persons involved in the installation, operation, and maintenance of this equipment should be thoroughly familiar with the contents of this manual. Keep this manual for reference and further use.

#### **⚠ WARNING**

To prevent personal injury, do not use the equipment shown in this manual to lift, support, or otherwise transport people, or to suspend unattended loads over people.

## TABLE OF CONTENTS

SECTION I	INTRODUCTION .....	3
1-1	General Information .....	3
1-2	Safety Standards .....	3
1-3	Hoist Construction .....	3
1-4	Basic Hoist Data .....	3
1-5	Application Information .....	3
SECTION II	INSTALLATION .....	3
2-1	Inspection Prior to Initial Use .....	3
2-2	Trolley Mounting .....	4
2-3	Testing .....	4
2-4	Initial Lubrication .....	4
SECTION III	OPERATION .....	5
3-1	General .....	5
3-2	Safety Rules .....	5
3-3	Attaching the Load .....	5
3-4	Lifting or Pulling the Load .....	5
3-5	Lowering the Load .....	5
SECTION IV	INSPECTION .....	6
4-1	General .....	6
4-2	Frequent Inspection .....	6
4-3	Periodic Inspection .....	6
4-4	Inspection of Hoist Not in Regular Use .....	6
4-5	Chain Inspection .....	6
4-6	Hook Throat Opening .....	7
SECTION V	MAINTENANCE .....	7
5-1	General .....	7
5-2	Lubrication .....	7
5-3	Chain Replacement .....	7
5-4	Thread Stop Adjustment .....	8
SECTION VI	SERIAL NUMBER AND PARTS LIST .....	11
SECTION VII	EXPLODED ILLUSTRATION .....	11
	DO'S AND DO NOT'S .....	18

## WARRANTY

Every hoist is thoroughly inspected and tested prior to shipment from the factory. Should any problems develop, return the complete hoist prepaid to your nearest Duff-Norton Authorized Warranty Repair Station. If inspection reveals that the problem is caused by defective workmanship or material, repairs will be made without charge and the hoist will be returned, transportation prepaid.

This warranty does not apply where: (1) deterioration is caused by normal wear, abuse, improper or inadequate power supply, eccentric or side loading, overloading, chemical or abrasive actions, improper maintenance or excessive heat; (2) problems resulted from repairs, modifi-

cations or alterations made by persons other than factory or Duff-Norton Authorized Warranty Repair Station personnel; (3) the hoist has been abused or damaged as a result of an accident; (4) repair parts or accessories other than those supplied by Duff-Norton are used on the hoist. Equipment and accessories not of the seller's manufacture are warranted only to the extent that they are warranted by the manufacturer. EXCEPT AS STATED HEREIN, DUFF-NORTON MAKES NO OTHER WARRANTIES, EXPRESS OR IMPLIED, INCLUDING WARRANTIES OF MERCHANTABILITY AND FITNESS FOR A PARTICULAR PURPOSE.

## SECTION I INTRODUCTION

### 1-1. General Information

This manual provides information for the safe operation and maintenance of Coffing Army Type Hand Chain Hoist. All persons operating or maintaining these hoists should be familiar with the information contained herein. Adherence to the precautions, procedures, and maintenance practices described should ensure long reliable operation. Suggestions for improvements to this manual are solicited.

### 1-2. Safety Standards

All persons concerned with the installation, operation, inspection and maintenance of this hoist are urged to read American National Standard ANSI B30.16. That standard contains important rules (some mandatory and some of an advisory nature) designed primarily to prevent or minimize injury and otherwise protect life, limb and property. You should especially be aware of the mandatory rules pertaining to inspection requirements and the advisability of maintaining written, dated and signed inspection reports and records. All applicable state and local codes for this product should be observed also.

### 1-3. Hoist Construction

This Coffing Hoist Army Type Hand Chain Hoist employs the Superoid gear transmission for strength and efficiency. Superoid gearing puts more teeth into contact under load than any other system of hoist gearing. Fewer parts are used, giving you increased hoist life and reducing maintenance. Gearing is made from alloy steel forgings. The

chain guides are malleable iron. Hooks are steel forgings and load chain is heat treated alloy steel. The hand chair wheel is one piece construction of aluminum alloy.

### 1-4. Basic Hoist Data

The operator should be aware of the basic hoist data in Table 1.

### 1-5. Application Data

This hoist is intended for general industrial use for lifting, pulling and tensioning-type applications within its rated load. Prior to installation and operation, the user should review his application for abnormal environmental or handling conditions and to observe the applicable recommendations as follows:

- a. **Adverse Environmental Conditions.** Do not use the hoist in areas containing flammable vapors, liquids, gases or any combustible dusts or fibers. Refer to Article 500 of *The National Electric Code*. Do not use this hoist in highly corrosive or abrasive environments. Do not use this hoist in applications involving extended exposure to ambient temperatures below  $-10^{\circ}\text{F}$  or above  $130^{\circ}\text{F}$ .
- b. **Lifting of Hazardous Loads.** This hoist is not recommended for use in lifting or transporting hazardous loads or materials which could cause wide-spread damage if dropped. The lifting of loads which could explode or create chemical or radioactive contamination if dropped requires fail-safe redundant supporting devices which are not incorporated into this hoist.

**TABLE 1. BASIC HOIST DATA**

Model Number	Rated Load (Lbs.)	Standard Lift (Ft.)	Minimum Headroom (In.)	Chain Pull in Lbs. to Lift Rated Load	Feet of Chain Overhauled to Lift Load One Ft.	Strands of Load Chain	Minimum Radius Curve (In.)
AT 1/2	1,000	8	10 <sup>3/16</sup>	39	24	1	21
AT 1	2,000	8	11	41	48	2	21
AT 1 1/2	3,000	8	14 <sup>5/8</sup>	62	58	1	21
AT 2	4,000	8	14 <sup>5/8</sup>	83	58	1	21
AT 3	6,000	8	19 <sup>1/8</sup>	64	116	2	21
AT 4	8,000	8	19 <sup>1/8</sup>	85	116	2	21
AT 5	10,000	8	21 <sup>5/16</sup>	72	174	3	48
AT 6	12,000	8	21 <sup>5/16</sup>	87	174	3	48
AT 8	16,000	8	20 <sup>3/4</sup>	90	232	4	48

## SECTION II INSTALLATION

### 2-1. Inspection Prior to Initial Use

Inspect the hoist for any evidence of shipping damage or loose parts. Perform the frequent inspections listed in paragraph 4-2. This should be done by or under the direc-

tion of a person familiar with hoist operation and industrial safety standards prior to initial use. All inspections of any kind should be logged or recorded, dated, signed and filed for reference purposes.

## 2-2. Trolley Mounting

- a. For the best possible wheel and beam life, Coffing® Army Type Trolley Hoist use different wheels for American Standard I-beams, Wide (flat) Flange beams and patented monorail track. Check that the trolley wheels match the contour of the flange.
- b. Standard Army Type Trolleys are adjustable for the flange widths of 3.33 to 6.00 inches. Adjustment for I-beam sizes and tolerance is accomplished by locating the spacer washers as shown in Figure 2-1. Normal placement of washers is given in Table 2-1.

**BEAM MANUFACTURING TOLERANCES ALLOW WIDE VARIATIONS FROM HANDBOOK FLANGE WIDTHS. SLIGHT CHANGES TO RECOMMENDED WASHER DISTRIBUTION MAY BE NECESSARY TO SUIT SPECIFIC INSTALLATIONS.**

The particular beam on which your hoist is to be installed should be measured and trolley spacer washers adjusted as required to achieve a wheel to beam flange clearance of  $\frac{3}{32}$ " to  $\frac{1}{8}$ ".

**CAUTION: Do not side load the hoist or restrict the housing or chain from forming a straight line with the direction of loading.**

## 2-3. Testing

Check the hoist through a few lifting and lowering cycles with no load on the hook. Attach a load of fifty pounds to the hook and check the hoist through a few lifting cycles. Operate the hand chain in the up and down direction. If operation is normal with this light load, test the hoist for operation with rated load, and then with about 125 percent of rated load.

## 2-4. Initial Lubrication

Lubricate trolley wheel gears (hand geared trolley) with NLGI-2 or heavier grease.

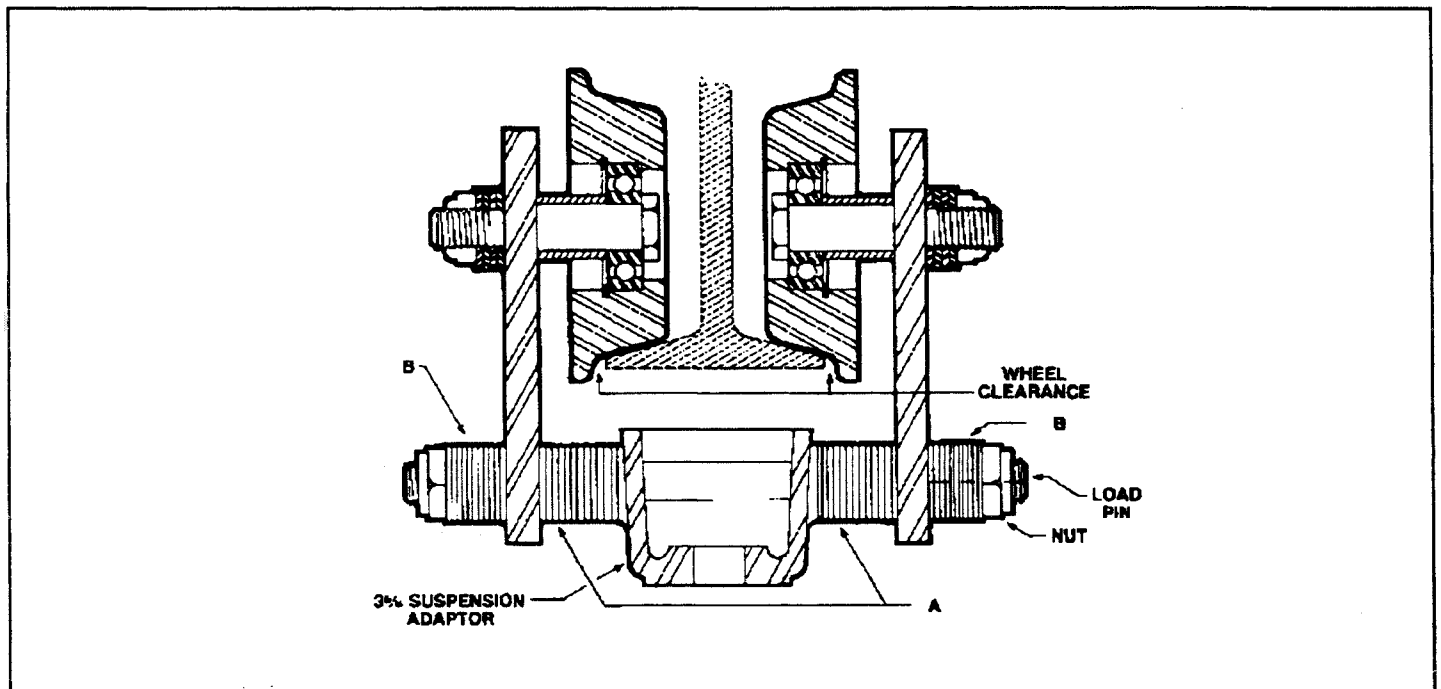

FIGURE 2-1

TABLE 2-1. TROLLEY I-BEAM ADJUSTMENT DATA

I-Beam* Size & Weight	Flange Width	Point A Washer Between Sus. Adapter & Sideplate		Point B Washers Between Sideplate & Nut		Actual Spacing Susp. Lug to Sideplate	Point C Clearance Wheel to Beam
		.135 Thick	.075 Thick	.135 Thick	.075 Thick		
6" - 12.5 #	3.330	3	5	8	5	.780	.097
6" - 17.25 #	3.565	5	3	6	7	.900	.100
8" - 18.4 #	4.000	5	6	6	4	1.125	.107
8" - 23.0 #	4.171	5	7	6	3	1.200	.097
10" - 25.4 #	4.660	8	5	3	5	1.455	.107
10" - 35.0 #	4.944	9	5	2	5	1.590	.100
12" - 31.8 #	5.000	7	9	4	1	1.620	.102
12" - 35.0 #	5.078	10	4	1	6	1.650	.093
15" - 42.9 #	5.500	11	5	0	5	1.860	.092
15" - 50.0 #	5.640	11	6	0	4	1.935	.097
18" - 54.7 #	6.000	11	9	0	1	2.160	.142

\*American Standard I-Beam

NOTE: All dimensions are in inches unless otherwise specified.

## SECTION III OPERATION

### 3-1. General

This section presents information concerning the proper operation of the Coffing® Army Type Hand Chain Hoist. It is not intended to serve as a handbook on rigging. Rigging, the process of moving heavy loads using mechanical devices, requires special knowledge and equipment. For information on the safe use of slings and similar rigging gear, users are urged to consult a textbook on rigging.

### 3-2. Safety Rules

Inspect the hoist for any sign of loose, broken, or malfunctioning parts. Any malfunctioning hoist should be tagged as "out of order" and removed from service until the defect is corrected.

- a. Do not overload the hoist.
- b. Do not exert more than the hand chain pull to lift rated load by one operator. The Hoist is designed to lift its rated capacity when a reasonable force is exerted. If effort appears to be excessive, recheck the load and use a larger capacity hoist if necessary.
- c. Do not side load the hoist. Always pull in a straight line between hooks. Side loading over a sharp corner may fracture the hoist housing or load block.
- d. Be sure there are no twists in the load chain and make sure that load chain is free to move and will clear all obstructions. On multiple chained hoist it is possible for the load block to be capsized or turned over one or more times causing the chain to twist.
- e. Do not operate the hoist from an off balance position. Operator should have firm footing or be otherwise secured before operating the hoist.
- f. Before raising or pulling a load, always check to see that it is held securely in the hook or sling chains, etc. Raise the load only until the load chain is taut and then recheck the rigging before continuing to raise the load.
- g. Make sure that the slings and other rigging have sufficient capacity to support the load, and are in good condition.
- h. **DO NOT STAND BENEATH A LOAD!** Do not move a load in such a manner as to endanger personnel.
- i. Do not leave the hoist under load for extended or unattended periods unless specific precautions have been taken to provide protection.
- j. Do not wrap the load chain around a load. **USE A SLING!**
- k. Do not **TIP-LOAD** any hook, as this will exert undue strain in the hook, resulting in hook failure.
- l. The hoist is designed for manual operation by one person. Do not attempt to operate hoist with other than the manual power furnished by one person.

- m. **DO NOT USE HOIST TO LIFT, SUPPORT OR OTHERWISE TRANSPORT HUMAN CARGO.**
- n. The hand chain is equipped with a safety link. When the safety link opens or deforms, stop at once and inspect for the cause.
- o. Lifting a load with two hoists is not recommended. If the operation is unavoidable, hoist the load with utmost care, keeping balance of the load.
- p. Never run the load chain out to far. When operated beyond the range of lift, an excessive load that can cause damage will be imposed on the hoist.
- q. Hoists are designed for lifting loads vertically and should not be used for horizontal or angle hoisting.
- r. Extreme temperatures will lower the toughness of the hoist. Loads should be hoisted very slowly and carefully.
- s. The hoisting operation should never be done with the bottom hook or load caught on a fixed object.
- t. Never use the chain or hook as a ground for welding.
- u. Use only genuine parts and chains supplied by the authorized distributor.
- v. Be sure that beam end stops are in place.

### 3-3. Attaching the Load

Attach the load to the hook by means of slings or other approved devices. Make sure the slings or other devices are seated properly in the saddle of the hook before lifting. Be sure the hook latch is closed and working properly. Never wrap the load chain around the load.

### 3-4. Lifting or Pulling the Load

To raise the load pull hand chain downward in a clockwise direction while facing the hand chain wheel housing. Take note of the following when lifting the load:

- a. Lift or pull the load a few inches and check to see that it is well balanced in the sling or other lifting device. Make sure the load chain is not kinked or twisted or that the load does not contact any obstruction.
- b. Lift or pull the load to the desired distance. Do not leave the hoist under load for extended or unattended periods unless specific precautions have been taken to provide protection.

### 3-5. Lowering the Load

To lower the load pull hand chain downward in a counter-clockwise direction while facing the hand chain wheel housing.

The end of the chain should not be allowed to pull on the dead end pin.

**CAUTION: Make sure that the slack end chain is free to move into the housing and will clear all obstructions. Do not extend bottom hook beyond the hoist rated lift.**

## SECTION IV INSPECTION

### 4-1. General

A planned inspection routine should be established for this hoist based upon frequency of use, severity of use, and environmental conditions. Some inspections should be made frequently (daily to monthly) and others periodically (monthly to yearly). It is strongly recommended that an Inspection and Maintenance Check List and Inspector's Report similar to those shown in Figures 5-4 and 5-5 be used and filed for reference. All inspections should be made by, or under the direction of a designated inspector. Special inspections should be made following any significant repairs or any operating occurrence leading one to suspect that the hoist's capabilities may have been impaired.

The existence of well-worn parts is sufficient reason for questioning safe operation not to mention the added costs to repair damage that will inevitably result if severe wear is permitted to continue. The parts most likely to first evidence wear are: the chain, and sheave, hooks and brake area.

### 4-2. Frequent Inspections

**CAUTION: Any unsafe condition disclosed by the inspection shall be corrected before operation of the hoist is resumed. Adjustments and repairs shall be done only by designated personnel.**

Perform the following inspections daily prior to initial use of the hoist. Also, observe during operation for any damage which might appear between regular inspections. Prior to inspection, clean parts as required.

- a. Inspect the hooks for deformations, chemical damage or cracks. Hooks damaged by chemicals, deformation or cracks, or having throat openings greater than the "Maximum Allowable Opening" shown in Figure 4-2 must be replaced. If the hook is twisted more than 10 degrees from the plane of the unbent hook, it must be replaced.
- NOTE: Any hook that is twisted or has throat openings in excess of those listed in Figure 4-2 indicates abuse or overloading of the hoist. Other load bearing components should be inspected accordingly.**
- b. Check for missing, bent or otherwise damaged hook latches.
- c. Check that hooks swivel freely.
- d. Check the chain for elongation (see section 4-5). If the chain has been elongated the hoist has probably been highly overloaded. A qualified service man should inspect the hoist for other damage or send the hoist to an authorized repair facility nearest you.
- e. Check load chain for gouges, nicks, weld spatter, corrosion and distorted links. Also check the chain for presence of foreign material and adequate lubrication.
- f. Check load chain reeving per Figure 5-3 making sure that there are no twists in the load chain.
- g. Check that the dead end pin or connection is secure.
- h. Check trolley wheels for excess wear.

### 4-3. Periodic Inspections

It is recommended that the following inspections be performed at one- to twelve-month intervals. The exact period of inspection will depend on frequency and type of usage. Determination of this period will be based on the user's experience. It is recommended that the user begin with a monthly inspection and extend the periods to quarterly, semi-annually or annually based on his monthly experience.

- a. Perform all the frequent inspections listed in paragraph 4-2.
- b. Check nuts, bolts and other hardware for looseness, stripped or damaged threads.
- c. Check load sheave and chain attachments for distortion, cracks and excessive wear.
- d. Check pawl for excessive wear, binding and worn bearing.
- e. Check pawl springs for breaks, corrosion and stretch.
- f. Check pawl stud for excessive wear and pawl retention.
- g. Inspect gear and pinion shaft for adequate lubrication, cracks, distortion, worn or broken teeth and damaged threads.
- h. Inspect bearings for adequate lubrication, distortion, cracks and excessive wear.
- i. Check housing, covers and swivel frames for cracks, distortion and damaged threads.
- j. Inspect the chain per paragraph 4-5.
- k. Check hooks for cracks using dye penetrant, magnetic particle or other suitable detection method.
- l. Load brake check ratchet and brake disc for excessive wear glazing or oil contamination.

### 4-4. Inspection of Hoist Not in Regular Use

If the hoist has been idle for one month or more, perform the inspections listed in paragraph 4-2. If the hoist has been idle more than six months, perform the inspections listed in paragraph 4-3.

### 4-5. Chain Inspection

Chain inspection and lubrication are the most important aspects of hoist maintenance. Removal of the chain from the hoist usually is not necessary, but the chain should be run through the hoist enough that every link is made visible for inspection.

- a. Check each link for gouges, nicks, weld spatter, corrosion and distortion.
- b. Inspect each link for wear to the diameter of the link (see Figure 4-1). The nominal link diameter is .250 inch for the chain on models AT $\frac{1}{2}$ , AT1 and .375 inch for models AT1 $\frac{1}{2}$  and up. If the diameter of any link of .250 chain is worn to less than .200 or .375 chain less than .300, the entire chain must be replaced.
- c. 1. Check the chain for overall wear or stretch by selecting an unworn, unstretched length of chain (at the slack end, for example). Let the chain hang vertically with a light load (about 20 lbs.) on the chain to pull

it taut. Use a large caliper to measure the outside length of a convenient number of links (about 12 inches). Measure the same number of links in a used section of chain and calculate the percentage increase in length of the worn chain.

2. If the length of the worn chain is more than 1½% longer than the unused chain (.015" per inch of chain measured), then the chain should be replaced. If the chain is worn less than 1½%, check it at several more places along its length. If any section is worn more than 1½%, the chain should be replaced.
- d. The chain used in this hoist is accurately calibrated to operate over the load sprocket and is very carefully heat treated for maximum wear life and strength.

### WARNING

1. Do not weld or use missing links to join hoist load chain.
2. Do not substitute another manufacturer's chain in this hoist.
3. Damage or wear, beyond the stated limits, to any portion of the chain requires that the entire length be replaced.

### 4-6. Hook Throat Opening

Use Figure 4-2 (at right) to check maximum allowable hook throat opening.

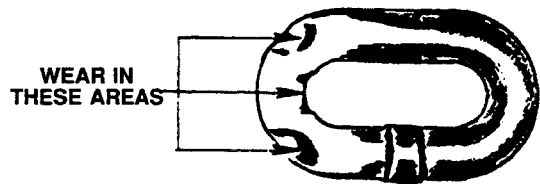
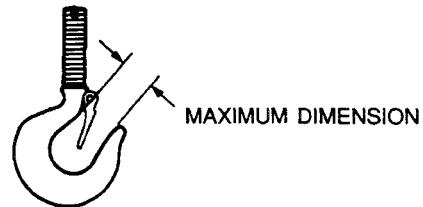

FIGURE 4-1. TYPICAL WEAR ON LINKS



Cap. (Tons)	REJECT HOOK OPENING
	Bottom
½	17/32"
1	17/32"
1½ & 2	123/32"
3 & 4	25/32"
5 & 6	25/32"
8	219/32"

FIGURE 4-2. HOOK THROAT OPENING

## SECTION V MAINTENANCE

### 5-1. General

This section provides instructions for the most common routine maintenance and adjustments. Major repairs are not within the scope of this manual and should be referred to qualified service facilities.

### 5-2. Lubrication

Proper lubrication is necessary for a long and relatively trouble-free hoist operation. Refer to the following and to Figure 5-1, Recommended Lubrication Schedule, for lubrication points, type of lubricant and frequency of lubrication.

- a. **Load Chain.** Clean the load chain with a non-acid and non-caustic solvent and coat with SAE 90 gear oil. Wipe excess oil to prevent dripping. If the hoist is used in an atmosphere containing abrasive dust, the chain should be cleaned and oiled more frequently. Never apply grease to the chain.
- b. **Bearings.** Load sheave and pinion bearings are factory sealed and prelubricated for life.
- c. **Hooks.** Allow a little oil to run down the shank to lubricate between the shank and the swivel or load block of the bottom hook.
- d. **Load Blocks.** For multiple chained hoists turn the load block on its side and allow a little oil to run down the load block shaft and into the roller bearings. Do this on both sides. Regrease bearings at least once yearly.

- e. **Gear Set.** Remove the old grease from the Superoid gear set at least once a year. Apply H-7593 grease to the teeth of the gear set.

**NOTE:** When removing the gear from the hoist, do not lose the shim(s) located between the gear and the bearing, as they control backlash of the gear set.

### 5-3. Chain Replacement

- a. If the chain has been removed from the hoist, and all inspection procedures have been followed, the chain should be installed in the hoist as follows:
  - b. The first link of the chain should be upstanding in the load sheave groove, so that the weld on the link faces away from the load sheave. The second link of the chain should ride in one of the load sheave pockets. Turn the hand chain wheel to rotate sheave. As the end of the chain moves around the sheave, take care so the chain will be guided through the shedder clearance hole. Attach the first link to the dead-end lug of the shedder, using the dead end pin. **DO NOT TWIST CHAIN!**
- c. **REMEMBER!**
  1. The weld on all upstanding chain links must face away from the load sheave.
  2. The chain should not be twisted or kinked between the load sheave or the dead end lug or throughout the reeving process.
- d. As above, after securing one end of the load chain to the

dead end pin in the shedder, the other end of the chain is to be stretched out to be sure all links are straight (no twist or kinks) and the end reeved through the idler sheaves as shown in Figure 5-3. The idler sheaves are free turning so the chain can be worked through by turning the sheaves with a finger while feeding the chain in. This can also be done by attaching a wire to the end of the load chain and working it around the sheaves one at a time. When this end of the chain is properly reeved secure the end of the chain to the attachment point with the dead end screw as indicated in Figure 5-3.

- e. A capacity load should be applied to the chain for final inspection. Under a loaded condition check for cracks or defects which would not otherwise be visible. This completes the chain inspection.

**5-4. Thread Stop Adjustment**

When replacing the hand chain wheel and hand chain, mount the chain so that the weld on the chain link is out away from the hand chain wheel. Mount all items in reverse of what they were disassembled. The front disc

must be in line with and touching the ratchet. The hand chain wheel is to be turned in a clockwise direction until ratcheting occurs. (Hand chain wheel should spin on freely.) **DO NOT BACK OFF!** Inspect to be sure that hub retaining ring is in place. Mount thread stop on spline so that the projection of the thread stop is 1/8" minimum to 1/4" maximum from the stop pin on the hand chain wheel. See Figure 5-2.

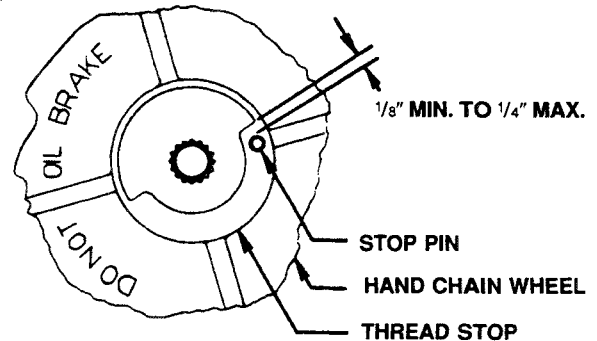

**FIGURE 5-2. LOCATION OF THREAD**

**RECOMMENDED LUBRICATION SCHEDULE\*  
MODEL AT ARMY TYPE HAND OPERATED CHAIN HOIST**

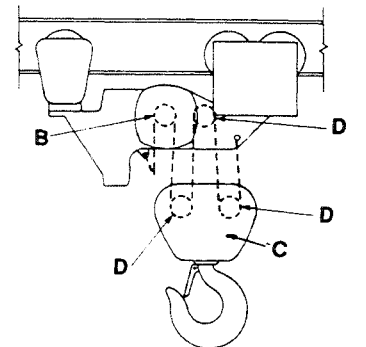
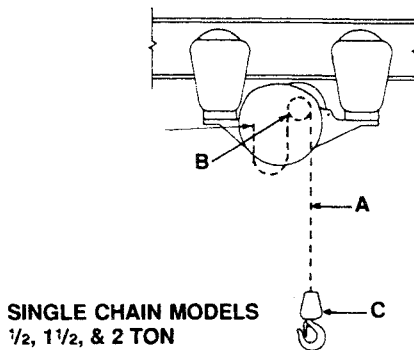

**NOTE:** Pinion and Load Sheave Bearings are prelubricated and sealed.

LUBRICATION POINT	COMPONENT	TYPE OF LUBRICANT	TYPE OF SERVICE AND FREQUENCY OF LUBRICATION		
			HEAVY	NORMAL	INFREQUENT
A	Load Chain	SAE 90 Gear Oil	Daily	Weekly	Monthly
B	Gearing	D-N No. H-7593 moly-grease Alternate—NLGI grade 1 or 2 gear grease with E.P. additive	At periodic inspection (See Figure 5)		
C	Hook Bearing	SAE 20-30 gear oil	Weekly	Monthly	Yearly
D	Idler Sheave Bearings	D-N No. H-7577 bearing grease Alternate—multi-purpose lithium base bearing grease	At periodic inspection (See Figure 5)		

\*This lubrication schedule is based on a hoist operating in normal environmental conditions. Hoists operating in adverse atmospheres containing excessive heat, corrosive fumes or vapors, abrasive dust, etc. should be lubricated more frequently

**FIGURE 5-1. RECOMMENDED LUBRICATION SCHEDULE**

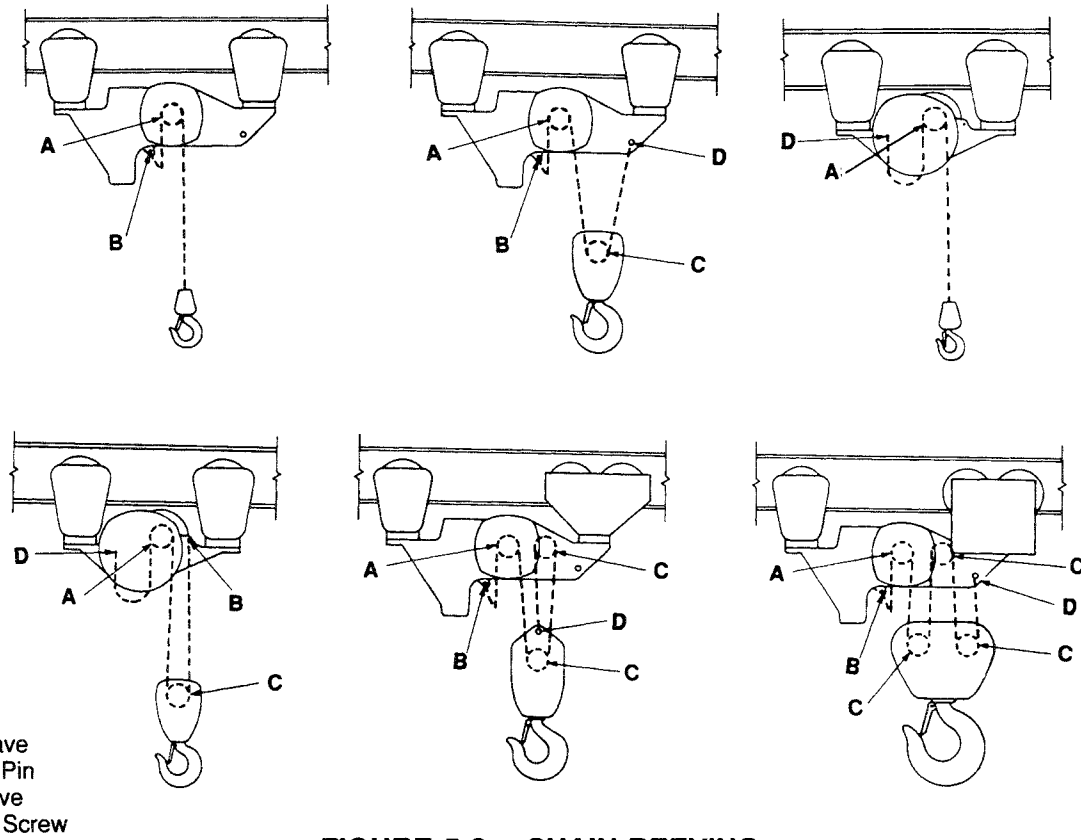

**FIGURE 5-3. CHAIN REEVING**

INSPECTOR'S REPORT			
ITEM	REMARKS (LIST DEFICIENCIES AND RECOMMENDED ACTION)		
INSPECTOR'S SIGNATURE	DATE INSPECTED	APPROVED BY	DATE

**FIGURE 5-4. RECOMMENDED INSPECTOR'S REPORT**

**INSPECTION & MAINTENANCE CHECK LIST  
HAND OPERATED OVERHEAD CHAIN HOIST**

TYPE OF HOIST \_\_\_\_\_ CAPACITY (TONS) \_\_\_\_\_  
 LOCATION \_\_\_\_\_ ORIGINAL INSTALLATION DATE \_\_\_\_\_  
 MANUFACTURER \_\_\_\_\_ MANUFACTURER'S SERIAL NUMBER \_\_\_\_\_

ITEM	FREQUENCY OF INSPECTION			POSSIBLE DEFICIENCIES	OK	ACTION REQUIRED
	FREQUENT		PERIODIC			
	DAILY	MONTHLY	1-12 MO.			
Load Chain	*	*	*	Inadequate lubrication, excessive wear or stretch, cracked, damaged or twisted links, corrosion or foreign substance		
Brake Mechanism	*	*	*	Slippage or excessive drift		
Hooks	*	*	*	Excessive throat opening, bent or twisted more than 10 degrees, damaged hook latch, wear, chemical damage, worn hook bearing, Cracks (use dye penetrant, magnetic particle or other suitable detection method)		
Hook Retainers			*	Worn or damaged nuts, collars, pins welds or riveting used to secure hook in load block or housing		
Brake Parts: Friction Discs  Pawl, Ratchet Pawl Springs Brake Hub Pawl Stud			*	Excessive wear, glazing, oil contamination Wear, binding, worn bushing Breaks, corrosion or stretch Wear or damaged threads Excessive wear, pawl retention		
Sheaves Hand Chain Wheel, Chain Attachments			*	Distortion, cracks, excessive wear		
Gearing			*	Inadequate lubrication, cracks, distortion, worn or broken teeth		
Bearings, Shafts			*	Inadequate lubrication, distortion, cracks, excessive wear		
Housing, Load Block			*	Cracks, distortion, loose bolts or nuts		
Nuts, Bolts, Rivets			*	Looseness, stripped or damaged threads		
Trolleys and Supporting Structure			*	Damage or wear which restricts ability to support imposed loads		
Capacity Plates Warning Labels			*	Missing, damaged or illegible		

NOTE: Refer to Maintenance and Inspection Sections of the Hoist Maintenance Manual for further details.

**PERIOD OF INSPECTION**

Frequent — Indicates items requiring inspection daily to monthly. Daily inspections may be performed by the operator if properly designated.

Periodic — Indicates items requiring inspection monthly to yearly. Inspections to be performed by or under the direction of a properly designated person. The exact period of inspection will depend on frequency and type of usage. Determination of this period will be based on the user's experience. It is recommended that the user begin with a monthly inspection and extend the periods to quarterly, semi-annually or annually based on his monthly experience.

**NOTE: This inspection and maintenance check list is in accordance with our interpretation of the requirements of the Safety Standard for Overhead Hoists ANSI B30.16—1973. It is, however, the ultimate responsibility of the employer/user to interpret and adhere to the applicable requirements of this safety standard.**

**FIGURE 5-5. INSPECTION AND MAINTENANCE CHECK LIST**

## SECTION VII EXPLODED ILLUSTRATION

The following exploded drawings provide a complete list of parts used in the standard Army Type Hoist Bottom Block Assemblies. Since different models and capacities are covered by this manual the item number and parts list will show each different part number with sufficient information to allow the selection of the correct part number.

ITEM NO.	PART NAME	CAPACITY TONS	PART NO.
1	King Bolt	All	700K6
		8	700K5
2	King Bolt Nut	All	H-3929
		8	H-3928P
3	Roll Pin	1/2-8	H-5235
4	Bottom Hook with Latch	1/2	3J20S
		1	3K8S
		1 1/2-2	SHL-26
		3-4	SHL-8
		5-6	SHL-15
8			SHL-16
		5-6	SHL-15
		8	SHL-16
5	Hook Nut	1/2	H-3986P
		1 1/2-2	H-3991P
		3-4	H-3924P
		5-6	H-3925P
		8	H-3923P
6	Hook Nut Pin	1/2	H-5159
		1 1/2-2	H-5232
		3-4	H-5235
		5-6	H-5256
		8	H-5257
7	Ratchet	1/2-1	MP-122
		1 1/2-8	CB-7-3
8	Load Sheave	1/2-1	CA-16-1
		1 1/2-8	CB-16-6
9	Sheave Nut	1 1/2-8	H-3682
10	Lock Washer	1 1/2-8	H-4068
11	Housing	1/2-1	CA-18-2
		1 1/2-8	CB-18-7
12	Bearing	1/2-1	CA-531
13	Load Chain	1/2-1	JL-19B
		1 1/2-8	C-19-12
14	Bearing	1/2-1	CA-520
15	Washer	1/2-1	CA-250
16	Ratchet Bearing	1/2-1	CA-530-1
17	Pawl	1/2-8	CB-902-3
18	Pawl Stud	1/2-8	RA-26
20	Pin Key	1/2-1	CA-103
21	Sheave	3-8	CB-28
22	Swivel Frame	1/2	JF-20-2
		1	HJ-30
		1 1/2	CB-20-4
		2	CB-21-3
		3-4	CB-30
		5-6	CB-30-4
		8	CB-30-2
22A	Swivel Frame	1/2	JF-20-3
		1 1/2	CB-20-5
		2	CB-21-2

ITEM NO.	PART NAME	CAPACITY TONS	PART NO.
23	Load Block Screw	1	H-4562
		1 1/2-2	H-2313P
		3-4	H-2411P
		5-8	H-2419P
24	Load Block Nut	1 1/2-2	H-3924P
		3-4	H-3965P
		5-8	H-3966P
25	Side Cover	1/2-1	CA-31-1
		1 1/2-8	CB-31-4
26	Screw	1/2-1	H-2941P
		1 1/2-8	H-1106P
27	Lockwasher	1/2-1	H-4082P
		1 1/2-8	H-4062P
28	Hand Wheel Cover	1/2-1	CA-32
		1 1/2-8	CB-32-6
29	Screw	1/2-1	H-1102P
		1 1/2-8	S-49-19
30	Lockwasher	1/2-1	H-4084P
		1 1/2-8	H-4085P
31	Dowel Pin	1 1/2-8	H-5382
32	Hand Chain Wheel	1/2-1	CA-33-1
		1 1/2-8	CB-33-6
33	Hub	1/2-1	CA-101
		1 1/2-8	CB-34-5
34	Retaining Ring	1/2-1	H-5531
		1 1/2-8	H-5502
35	Chain Guide	1 1/2-8	CB-36-1
36	Chain Guide Pin	1 1/2-8	H-5254
37	Chain Shedder	1 1/2-8	MA-37-1
38	Dead End Pin	1 1/2-8	H-5133P
39	Chain Shedder Pin	1 1/2-8	H-5126
40	Retaining Ring	1/2-1	H-5502
41	Retaining Ring	5-8	H-5514
42	Hand Chain	1/2-1	ML-19
		1 1/2-8	53-A
43	Spring	1/2-8	B-67
44	Roll Pin	1/2-1	H-5232
		1 1/2-8	H-5235
45	Load Block Shaft	3-8	CB-100
46	Retaining Ring	1/2-1	H-5506
47	Roll Pin	3-8	H-5235
48	Screw	1/2-1	S-49-12
49	Lockwasher	1/2-1	H-4084-P
50	Washer	1/2-1	H-4002P
51	Bearing Retainer	1 1/2-8	CB-250-1
52	Screw	1 1/2-8	H-2952
53	Thread Stop	1/2-1	CA-252
		1 1/2-8	CB-251

ITEM NO.	PART NAME	CAPACITY TONS	PART NO.
54	Roll Pin	1/2-1	H-5233
		1 1/2-8	H-5263
55	Cotter Pin	1	H-5029P
56	Hook Washer	3-4	CB-252-2
		5-6	CB-252-3
		8	CB-252-4
57	Shim	1 1/2-8	CB-254-1
58	Washer	3-8	CB-255
59	Gear	1/2-1	CA-420-3
		1 1/2-8	CB-482-3
60	Pinion	1/2-1	CA-400-2
		1 1/2-8	CB-483-2
61	Bearing	1/2-1	CA-502
		1 1/2-8	CB-504-1
62	Bearing	1 1/2-8	CB-505
63	Hook Bearing	1/2	JF-510
		1 1/2-2	JF-511
		3-4	CB-511
		5-6	CB-511-1
		8	CB-511-2
64	Bearing	1	530J33
		3-8	CB-521
67	Brake Disc	1/2-1	CA-580-1R
		1 1/2-8	CB-580-6
67A	Brake Disc	1/2-1	CA-581-1

ITEM NO.	PART NAME	CAPACITY TONS	PART NO.
68	Capacity Decal	1/2	675K94
		1	675K95
		1 1/2	675K96
		2	675K97
		3	675K98
		4	675K99
		5	675K100
		6	675K101
69	Capacity Decal	8	675K102
		5	CB-675-8
		6	CB-675-9
70	Coffing Decal	1 1/2-8	677K17
71	Duff-Norton Decal	1 1/2-8	676K22
72	Lockwasher	1 1/2-2	H-4135
73	Dead End Screw	1/2	JF-700
		1 1/2-4	CB-700-1
		5-6	CB-700-2
		8	CB-700-1
75	Nut	5-6	H-3965P
78	Pawl Spring	1 1/2-8	CB-312-1
80	Washer	1/2-8	H-4216
81	Latch Kit	1/2	H7540
		1	H7540
		1 1/2-2	H7544
		3-6	H7545
		8	H7546
82	Retaining Ring	1/2-8	H-5568
83	Warning Decal	1/2	687K1
		1	687K4
		1 1/2-2	687K2
		3-8	687K4

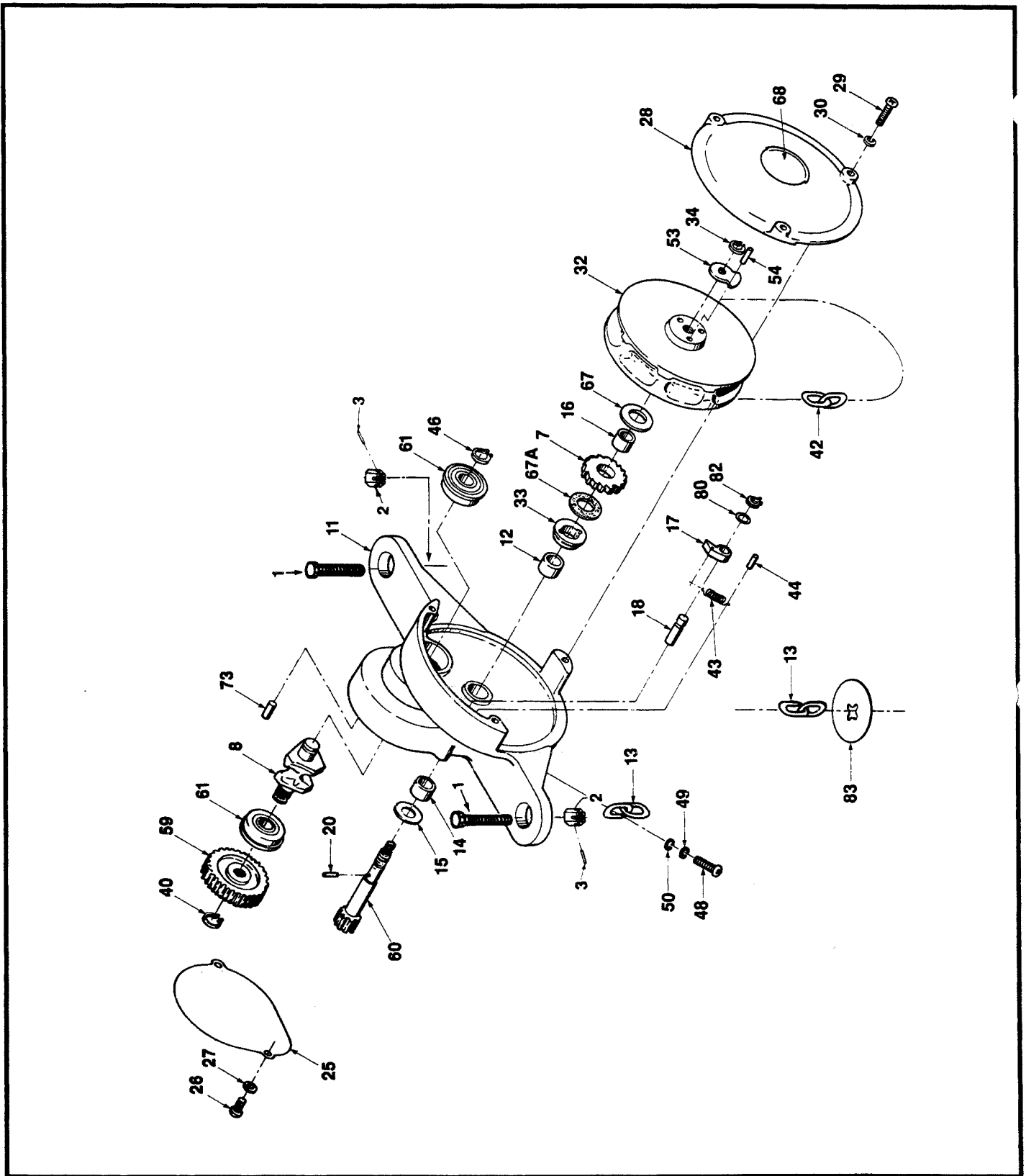

FIGURE 7-1. 1/2 - 1 TON

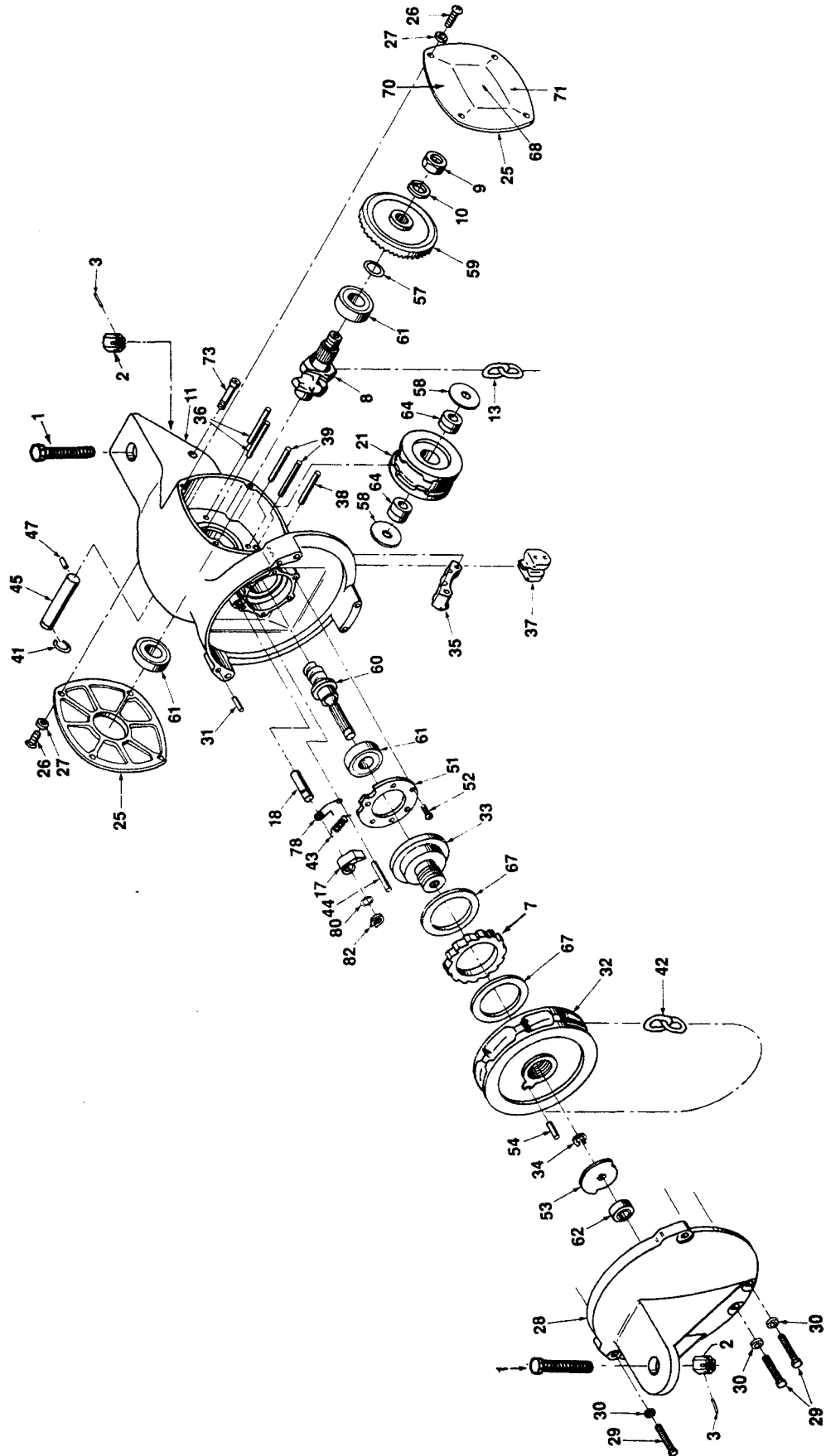

FIGURE 7-2. 2 THRU 8 TON

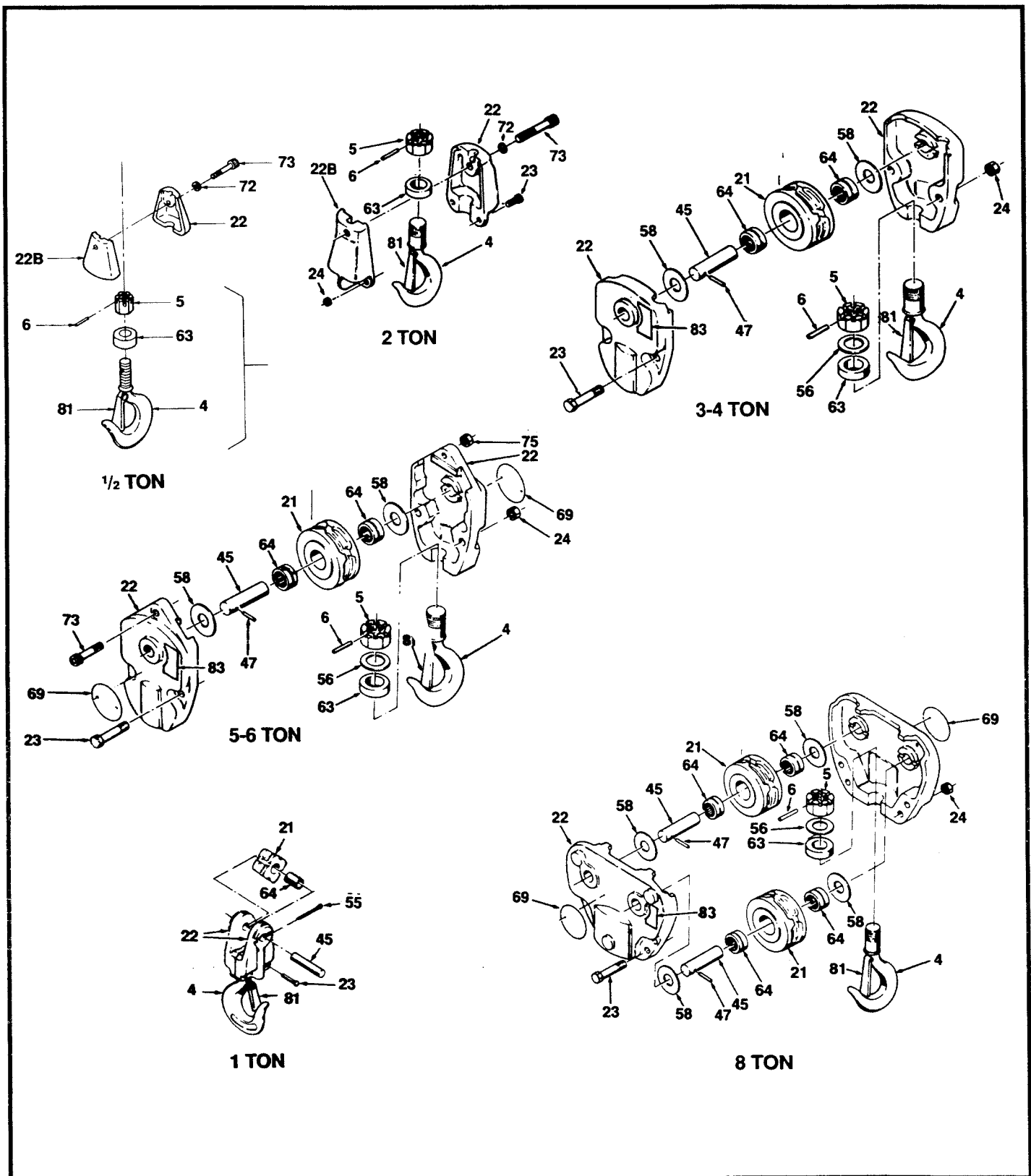

FIGURE 7-3. BOTTOM BLOCK ASSEMBLIES

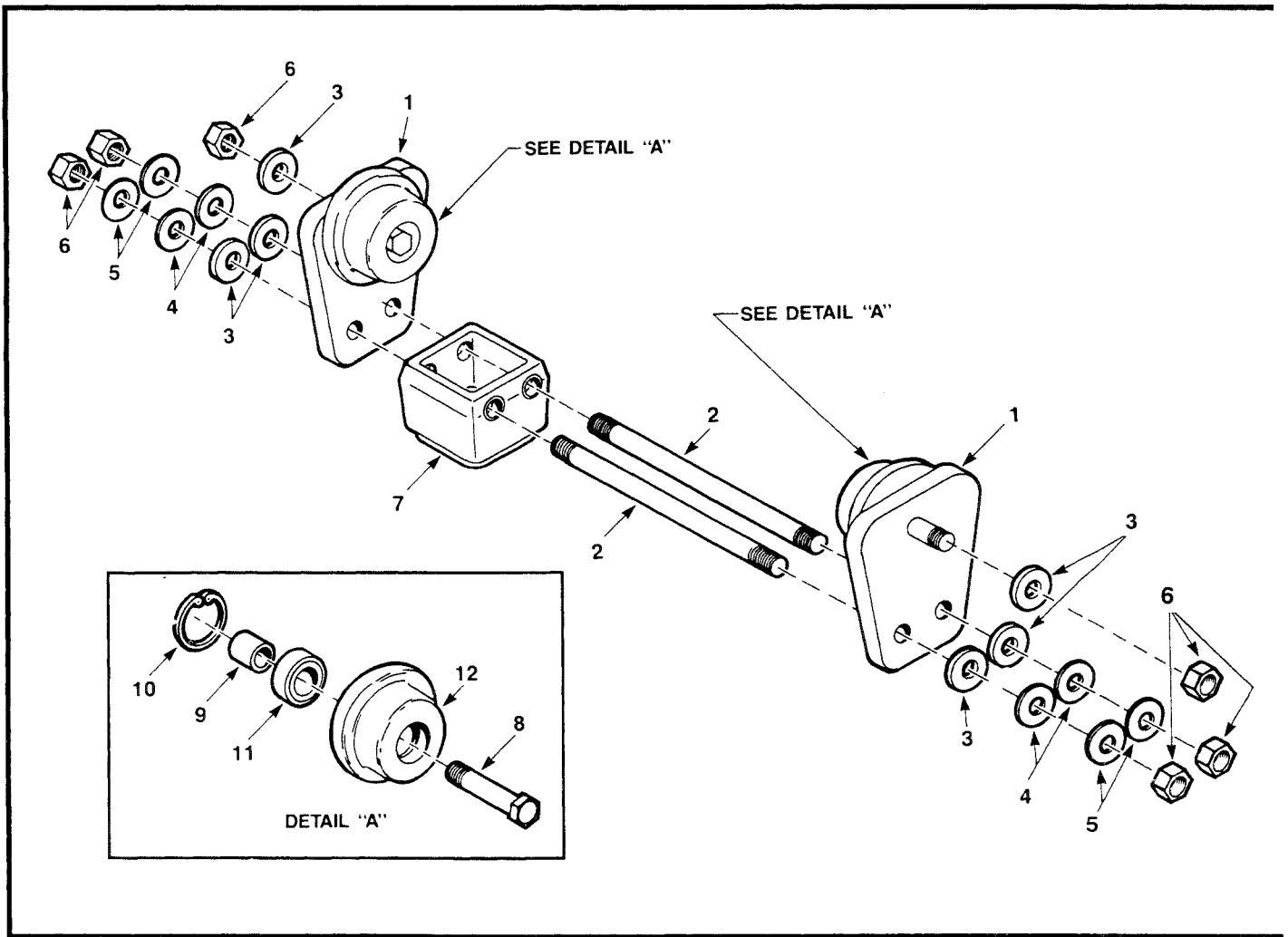

FIGURE 7-4. TWO-WHEEL TROLLEY

Index No.	Part Name	Part No.
1	Side Plate	5K56
2	Load Pin	103K1
3	Washer (1/8 Thick)	H-4211
4	Washer (10 ga.)	H-4209
5	Washer (14 ga.)	H-4210
6	Nut	H-3945
7	Suspension Box	50J33
8	Axle	102K1
9	Spacer	200K1
10	Retaining Ring	H-5528
11	Bearing	500K4
12	Wheel	45K10

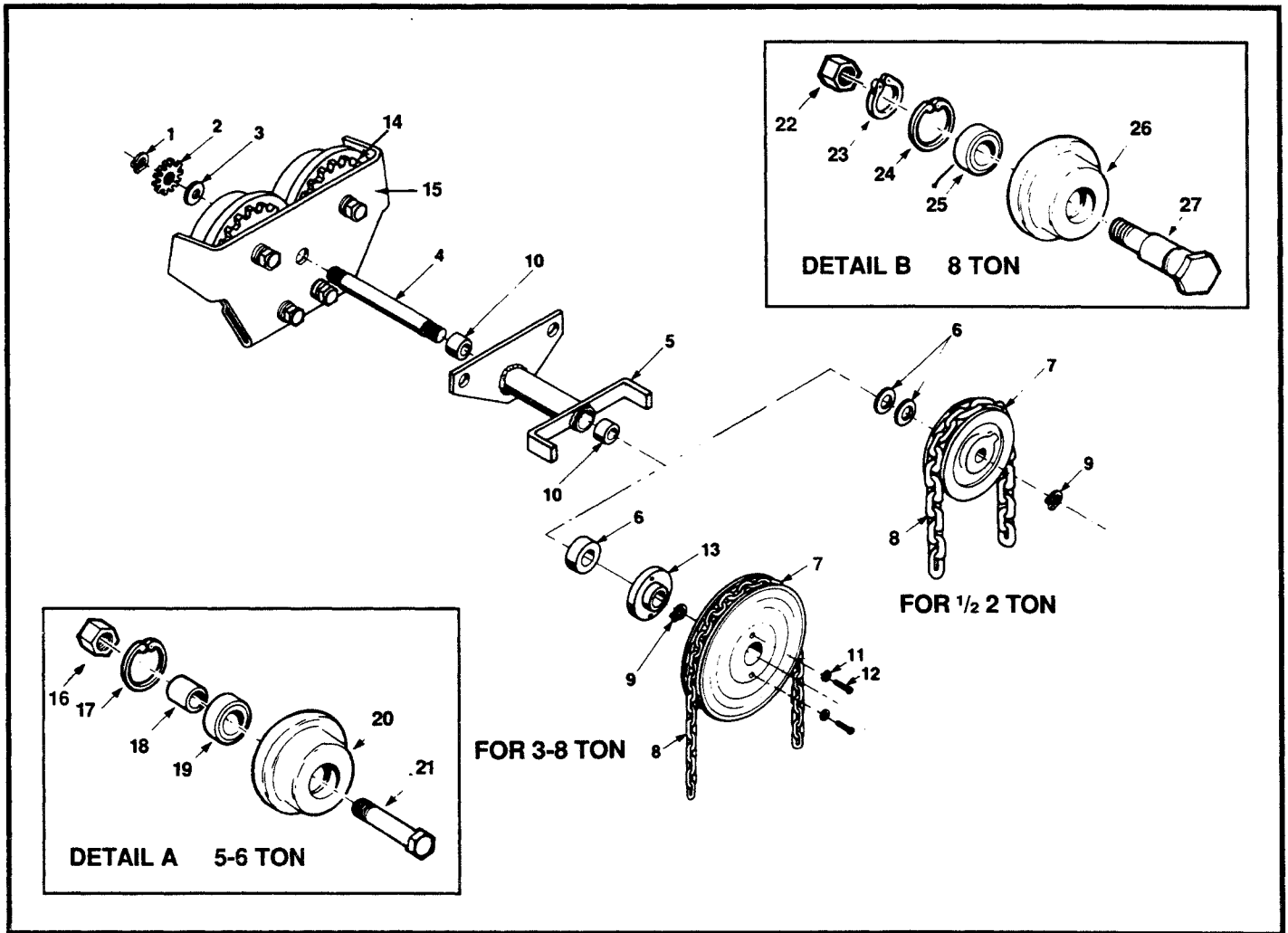

FIGURE 7-5. FOUR-WHEEL TROLLEY

Index No.	Part Name	Part No.	Index No.	Part Name	Part No.
1	Retaining Ring	H-5501	15	Side Plate Weldment	
2	Pinion	420K1		5-6 Ton	5KG4
3	Spacer Bearing (1/16 Thick)	525K2		8 Ton	5K78
4	Gear Shaft	100K14-2	16	Nut	H-3945
5	Sleeve and Adapter Assembly:		17	Retaining Ring	H-5528
	2 Ton Under	51KG1-3	18	Spacer	200K1
	3 Ton Up	51KG2-3	19	Bearing	500K4
6	Spacer Bearing	525K1	20	Wheel:	
7	Hand Chain Wheel:			Plain	45K10
	2 Ton	33K2		Drive	45K1
	3 Ton	33K13	21	Axle	102K1
8	Hand Chain (Specify Length)	53A	22	Nut	H-3946
9	Retaining Ring	H-5527	23	Retaining Ring	H-5529
10	Sleeve Bushing	530K6	24	Retaining Ring	H-5530
11	Washer	H-4138	25	Bearing	500K5
12	Bolt	H-2304	26	Wheel:	
13	Hub Adapter	51K4		Plain	45K20
14	Gear	420K2		Drive	45K2
			27	Axle	102K9

## DO'S AND DO NOT'S

### Hand Chain Manually Operated Chain Hoists

The following warnings and operating practices have been taken from American National (Safety) Standards ANSI B30.16 and are intended to avoid unsafe hoisting practices which might lead to personal injury or property damage.

These recommendations apply to all hand chain manually operated chain hoists for vertical lifting service involving material handling of freely suspended unguided loads.

#### WARNING: TO AVOID INJURY

1. **DO** read ANSI B30.16 Safety Standard for Overhead Hoists and the Hoist Manufacturer's Operating and Maintenance Instructions.
2. **DO** be familiar with hoist operating controls, procedures and warnings.
3. **DO** make sure the hoist suspension hook is securely attached to a suitable support.
4. **DO** maintain firm footing or be otherwise secured when operating hoist.
5. **DO** make sure that load slings or other approved attachments are properly sized and seated in the hook saddle.
6. **DO** make sure the hook latch, if used, is closed and not supporting any part of the load.
7. **DO** make sure that load is free to move and will clear all obstructions.
8. **DO** take up slack carefully, check load balance, lift a few inches and check load holding action before continuing.
9. **DO** make sure that all persons stay clear of the suspended load.
10. **DO** avoid swinging of load or load hook.
11. **DO** protect load chain from weld spatter or other damaging contaminants.
12. **DO** promptly report any malfunction, unusual performance or damage of the hoist.
13. **DO** inspect hoist regularly, replace damaged or worn parts, and keep appropriate records of maintenance.
14. **DO** use the hoist manufacturer's recommended parts when repairing a hoist.

15. **DO** use hook latches wherever possible.
16. **DO** apply lubricant to load chain as recommended by the hoist manufacturer.
17. **DO NOT** lift more than rated load.
18. **DO NOT** use the hoist load limiting device to measure the load.
19. **DO NOT** use damaged hoist or hoist that is not working correctly.
20. **DO NOT** use hoist with twisted, kinked, damaged or worn chain.
21. **DO NOT** lift a load unless chain is properly seated in chain wheel(s) or sprocket(s).
22. **DO NOT** use load chain as a sling or wrap load chain around the load.
23. **DO NOT** lift a load if any binding prevents equal loading on all supporting chains.
24. **DO NOT** apply the load to the tip of the hook.
25. **DO NOT** operate unless load is centered under hoist.
26. **DO NOT** operate hoist with other than manual power.
27. **DO NOT** permit more than one operator to pull on a single hand chain at one time.
28. **DO NOT** allow your attention to be diverted from operating the hoist.
29. **DO NOT** operate hoist beyond limits of load chain travel.
30. **DO NOT** use hoist to lift, support or transport people.
31. **DO NOT** lift loads over people.
32. **DO NOT** leave a suspended load unattended unless specific precautions have been taken.
33. **DO NOT** allow sharp contact between two hoists or between hoist and obstructions.
34. **DO NOT** allow the chain or hook to be used as a ground for welding.
35. **DO NOT** allow the chain or hook to be touched by a live welding electrode.
36. **DO NOT** remove or obscure the warnings on the hoist.
37. **DO NOT** adjust or repair a hoist unless qualified to perform hoist maintenance.
38. **DO NOT** attempt to lengthen the chain or repair damaged load chain.

Reprinted with the permission of the Hoist Manufacturing Institute.

# COFFING® HOISTS

Coffing Hoists • Country Club Road • P.O. Box 779 • Wadesboro, NC 28170 USA  
Customer Service: Tel. (800) 477-5003 (704) 694-2156 • FAX (800) 374-6853 (704) 694-6829